

POTENTIOMETRIC ERROR DETECTOR MODEL : PED -01

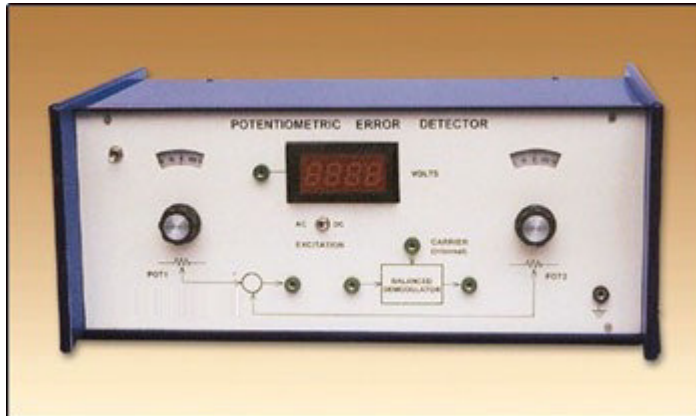

- High quality servo potentiometers
- 360° Mechanical, 355° Electrical span
- DC and AC operation
- 3½ Digital Panel Meter for all measurements
- Weight : 4 Kg Approximately
- Dimension : 250mm × 350mm × 150mm

INTRODUCTION

All feedback control systems operate from the error signal which is generated by a comparison of the reference and the output. Error detectors perform the crucial task of comparing the reference and output signals. In a purely electrical system where the reference and output are voltages, the error detector is a simple comparator. In some other systems with non-electrical outputs, the output signal is converted into electrical form through a measurement or transducer block, and then error detection is performed on the electrical signals. A position control system, with both input and output variables as mechanical positions (linear or angular), may however consist of two potentiometers - reference and output, which function as an error detector. Other devices which could be used in similar applications include synchro sets (for A.C. systems), sine-cosine potentiometers, hall effect-potentiometers etc, which unfortunately are not readily available.

The present set-up is designed to study the important characteristics of a 2-potentiometer angular position error detector. These include (i) linearity, (ii) sensitivity and (iii) maximum angle of rotation. Good quality wire wound servo potentiometers with full 360° rotation have been used for this purpose. Accurately marked dials with least count of 1° are fixed on the shafts for position indication. The error voltage is read on a built-in 3½ digit DVM. An I.C. regulated internal reference voltage is available for D.C. studies. When used with an A.C. reference, the unit also demonstrates the phase reversal of the error signal which is important in applications involving a 2-phase servomotor as actuator.

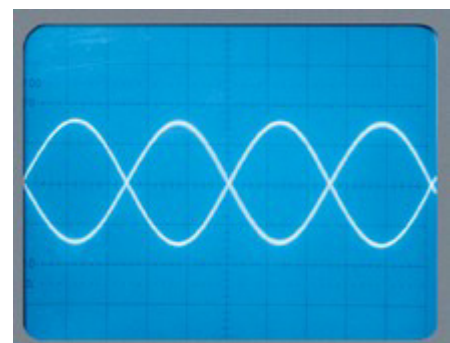

EXPERIMENTS:

- Linearity study of the error detector
- Determination of error detector gain
- Use of A.C. supply for the error detector introduction to the phase reversal of error signal

VIJAYANTA TECHNOLOGIES PVT. LTD.

(Formerly Vijai Electronics)

Dr. Baldev Singh Marg 28/147 Civil Lines, Roorkee-247667 Distt. Haridwar, Uttarakhand

Phone No.: 01332 - 272509, 7579200827

E-Mail : vijayantatechologies@gmail.com, vijaielectronics1965@gmail.com

FEATURES AND SPECIFICATIONS

- High quality servo-potentiometers of 360° shaft rotation
- Built-in signal and power sources
- 3½ digit DVM for measurements
- 220V±10%, 50Hz mains operation
- Requires an external CRO for A.C. studies

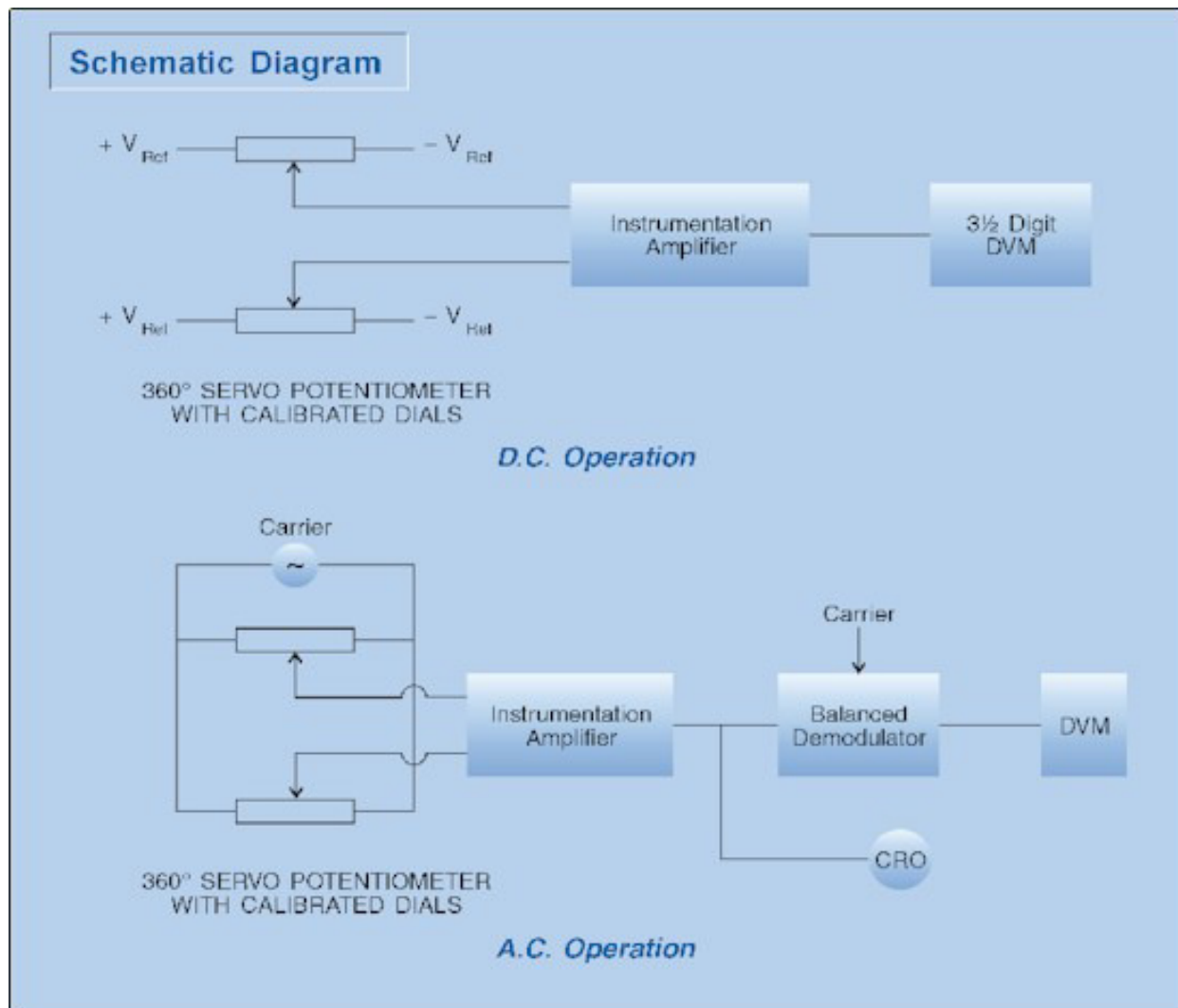

Note: There may be any change in specification due to continuous R & D without notice.

VIJAYANTA TECHNOLOGIES PVT. LTD.

(Formerly Vijai Electronics)

Dr. Baldev Singh Marg 28/147 Civil Lines, Roorkee-247667 Distt. Haridwar, Uttarakhand

Phone No.: 01332 - 272509, 7579200827

E-Mail : vijayantatechologies@gmail.com, vijaielectronics1965@gmail.com